

# RTSA SA CHAPTER NEWSLETTER

September 2011 Edition



**NEXT MEETING: Dry Creek Railcar Maintenance depot – Site Visit**

**Next meeting –Thursday 6<sup>th</sup> October 2011**

## **PTS and BTA**

Dry Creek depot has been officially open since 7<sup>th</sup> May 2011 although the site was actually occupied mid February 2011. The site replaces the original Maintenance Depot just south of Adelaide Railway station which has been demolished to make way for the new hospital on that location.

Dry creek depot is currently stabling the existing diesel powered 2000 and 3000 class railcars and is being fitted out to accept the new Electric powered 4000 class railcars



Bombardier will be hosting the visit where members will have the opportunity to see all aspects of a working maintenance depot and enjoy a BBQ on completion.



Please note that sturdy fully enclosed footwear and a 'HI VIS' safety vest must be worn during the inspection of facilities.

## **TECHNICAL PRESENTATION**

### **VENUE:**

PTS Dry Creek Railcar  
Maintenance Depot  
Dean Harvey Drive, Dry  
Creek, Adelaide

### **DATE:**

Thursday 6<sup>th</sup> October 2011

### **TIME:**

3.30pm

Light Refreshments will  
be provided in the form of  
a BBQ at the site.



**ENGINEERS  
AUSTRALIA  
RTSA**



# RTSA SA CHAPTER NEWSLETTER

September 2011 Edition



## CONTENTS

<b>Editorial</b>	3
<b>Chairman's Chatter</b>	4
<b>Meet the team</b>	5
<b>Future Events</b>	6
<b>News - Light Rail Australia</b>	7
<b>News - Light Rail UK</b>	8
<b>News – High Speed Rail - China</b>	9
<b>News –International Rail Tourism</b>	10
<b>Last Month's Presentation</b>	11

## CHAPTER MEETINGS 2011

### Thursday 3<sup>rd</sup> November 2011

Ian Fox, Phil Campbell

ARTC

Train Planning (CORE paper)

### Tuesday 29<sup>th</sup> November 2011

Dr David Cruickshanks-Boyd

Hyde Park Hotel

### Publisher

This newsletter is a publication of the South Australian Chapter of the Railway Technical Society of Australasia. Opinions expressed within are not necessarily those of the Chapter, Society or Editor.

### Contributions

Contributions, including news, opinions, or letters to the Editor, are always welcome. Send material by e-mail to [saeditor@rtsa.com.au](mailto:saeditor@rtsa.com.au)

### Continuing Professional Development

Engineers Australia members are reminded that attendance at RTSA technical meetings contributes towards CPD requirements. Each RTSA technical meeting generally has a value of 1 CPD point.

### RTSA Website

The RTSA website [www.rtsa.com.au](http://www.rtsa.com.au) has details of RTSA activities, including future meetings and reports from past meetings, for all Chapters. Membership information for potential new members and an application form may be found at [www.rtsa.com.au](http://www.rtsa.com.au).

### Chapter Contacts

Chairman – Daniel Martucci

Ph: 8204 8213

Secretary – Peter Haskard

Ph: 8218 4033

Treasurer – Alice Weatherford

Ph: 8217 4224

Newsletter Editor - Russell Fuller

Ph: 7129 8283



ENGINEERS  
AUSTRALIA  
RTSA



# RTSA SA CHAPTER NEWSLETTER

September 2011 Edition Editorial



## HI VIS Jackets/bibs

If anyone who is attending the Dry Creek Depot has a 'HI VIS' jacket or vest will they please bring it along with them. Whilst spaces for the visit are not limited the number of spare 'HI VIS' vests are.

There has not been any correspondence to the SA chapter this month. I would remind all our members that we welcome correspondence of all kinds; news, points of interest, activities that members may be interested in or our member's thoughts and views on recent rail related engineering events.

The presentation given by George Erdos from the ATSB at the Joint meeting with IRSE and PWI on the 1st September 2011 is provided at the end of this newsletter for those who may have missed it.

It is my intention that any future presentations of this nature will be made available on the RTSA website under the SA chapter 'tab'.

I am advised that this will have to wait until the website has been updated and site access is secured by member log in.

In this month's chatter Daniel delves into the murky waters of pride, both self and civic. He seeks to give substance to the sense of how individuals feel the presence and absence of it.

I feel that, if we asked the general public for their opinion of what a good "vanity project" would be; we may be somewhat disappointed by the responses

As regards pride I wonder if, in this modern age, we are frightened to express it.



**Russell Fuller – Newsletter Editor, RTSA SA Chapter**

# RTSA SA CHAPTER NEWSLETTER



## Chair's Chatter: What value do you put on 'pride'?

**Some time ago** I wrote a column observing the ironic parallels between the cost-benefit analysis used by economists and the quest for impartial objectivity valued by Engineers. I said ironic as I also observed that these two disciplines haven't always seem to have shared such mutual respect.

Late last year we also heard the CORE keynote address reiterated to our Chapter by speaker Andrew McNoughton. His wise words were legion, but they included the observation of how certain ambitious high-speed railway initiatives seemed, in his words, "vanity projects" – an amusing bit of hubris at best, a disturbingly extravagant bit of populism at worst.

Lastly, we recently saw the good, bad and ugly in how society "considers its surroundings"... The excitement evident in our little presentation on the 4000-Class EMUs. The crestfallen Chinese reaction to the Wenzhou accident on their otherwise phenomenal HSR. The UK descending into a level of anarchy made all the more surprising by those in the business of making excuses. The memorialising of someone within a year of voting age who died after falling from a Southern Expressway bridge while trying to "tag" (ie competitively vandalise) it.

In light of these three ingredients, I realised my last column could be extrapolated thus:

*'Pride', for want of a better word, ought to be monetised.* For too long it has been economically invisible for society to have, feel and benefit from it.

Granted, it is a soft, intangible and subjective quality - scoffed-at by rationalists and dangerously unAustralian for some down-to-earth ocker types. *But worth nothing it is not* for a household, community or nation to identify positively with its surroundings; meeting this human need with policies and infrastructure is a KPI for any collective. In this year of human(itarian) engineering we should acknowledge this.

This is about people. The Chinese feeling so fiercely proud of their HSR that uniformed staff honour arriving trains with a salute. Compare that to young neighbours of the Southern Expressway feeling so differently about their public infrastructure that they hurl stones and abuse at staff removing the 'work' of the now-enshrined graffiti 'artist..

This is about people. That they can see a physical, iconic statement of achievement by their own species. Compare that to them being indoctrinated into considering "achievement" as an absolute *lack* of any impact – indeed that they are the only species in nature not entitled to leave any trace that they ever existed.

This is about people. How their unified, steadfast ambitions can yield a superlative accomplishment and a subtle, ongoing inspiration to their future generations. Compare that to how the nihilistic, moral-relativist ideals of no necessary norms, rules, or laws can develop a mood of cynicism at a perceived pointless existence - and despair at its baffling, limitless array of choices without winners.

People are human too. Perhaps they need a "vanity project" every now and then. If the wider economic benefits of a proud society were, somehow, monetised, could some of these endeavours actually be viable?

**In other news**, the Gawler Line beyond Mawson Lakes is about to start a seven-month closure for track rebuilding and installation of electrification masts.

**Daniel Martucci – Chair, RTSA SA Chapter**



# RTSA SA CHAPTER NEWSLETTER

September 2011 Edition Meet the Team



This month we spotlight Carolyne Southern one of the longer standing SA Chapter Committee members.



Carolyne moved to Australia in 1981 with her family and has taken after her father also studying Engineering, but diverged from the family business into Rail. She graduated from the University of South Australia in 1997 as a Mechanical Engineer.

She began her career on the refurbishment of the Port Stanvac Refinery but midway through this project was re-posted to Batangas in the Philippines to work on a similar project, which was an eye-opener; living in an area of third world poverty within an expat compound. The experience gained in the six months posting was invaluable

Carolyne took a position with ARTC in 1998 in the Engineering and Infrastructure Group. In 2004 Carolyne moved to Pacific National where she is currently employed as the Manager Technology and Systems within the Asset Management Group.

Carolyne is the current chairman of the Wayside Steering and Noise Abatement Committees and RISSB Rolling stock Committee deputy chair

Carolyne is a keen traveller who has now been to every continent except Antarctica, (which is on the list) she also lists bushwalking, home renovation and photography among her interests.

# RTSA SA CHAPTER NEWSLETTER

September 2011 Edition - Future Events



## Advance Notification of next year's RTSA Awards

Please note that nominations for the 2012 Railway Engineering Student Thesis Award and the Wheel-Rail Interface Award are now being taken.

For both awards the closing date is Friday 24th November 2011.

## AusRAIL PLUS 2011 22nd – 24th November 2011 Brisbane Convention & Exhibition Centre

100 senior and technical rail executives addressing the conference agenda

Over 300 exhibitors filling 15000sqm of the Brisbane Convention and Exhibition Centre

Over 1000 representatives from across the rail spectrum attending the conference  
Over 3000 trade visitors moving through the exhibition hall

## CORE 2012 - Call for Papers Closing Soon

You have less than a month left to submit your abstract for consideration in the CORE 2012 Program.

CORE has a reputation for high quality objective papers and presentations which advance the body of knowledge on rail technologies and provides a forum for the sharing of best practice in planning, implementation, operations and management of rail systems.

Both awards attract prizes of:  
\$4000;  
A plaque; and  
One year's free membership of the RTSA.

Full details can be found in the March newsletter.

During the three days, speakers from all over the world will deliver presentations on cutting edge developments in customer relations and the very latest innovations essential to the future of rail

Highlights of AusRAIL PLUS 2011 include:

- Rail Suppliers CEO Forum
- AusRAIL PLUS 2011 exhibition with over 300 companies
- ARAs AusRAIL PLUS Gala Dinner
- RTAAs AusRAIL PLUS Yellow Tie Dinner

Be sure to submit your abstract by Friday 14 October 2011.

Full details available on the Conference Web Site

# RTSA SA CHAPTER NEWSLETTER

September 2011 Edition Light Rail Australia



## Greens want ACT to go hard on light rail

The ACT Greens have called on the Government to reverse its failure to pursue long-mooted plans for a Canberra light-rail network.

The Greens say since the ACT Government's bid for Commonwealth funding for a light-rail network in 2008, it has failed to progress those plans since then. Instead, the Government has made concerted bids for roads funding from Infrastructure Australia, winning support for its Majura Freeway.

Transport spokeswoman Amanda Bresnan will this week move a motion in the Legislative Assembly calling for the Government to commit to building light rail in Canberra, and to make a strong case to the Federal Government for high-speed rail. She will also call on the Government to tap into the

Federal Government's current study into an east coast high-speed rail network.

Ms Bresnan says the Government should position the ACT to take advantage of the rare opportunity, and present a detailed proposal to the Federal Government by the end of the year, and make the case for prioritising Canberra routes.

"The Chief Minister has lobbied and pushed for new freeways," Ms Bresnan said. "Sustainable transport projects like light rail and high-speed rail should receive the same effort."

It is estimated that there are 2million trips between Canberra and Sydney every year. A spokeswoman for Transport Minister Simon Corbell said the Government would consider the proposal.

<http://www.canberratimes.com.au/>



# RTSA SA CHAPTER NEWSLETTER

September 2011 Edition - Light Rail UK



## New trams for a new era World unveiling of Flexity 2 tram - in Blackpool



*Flexity 2 No. 001 making its first run with passengers on the Blackpool sea front. In the background is the new Starr Gate depot.*

Britain's favourite seaside resort, Blackpool, has hosted the unveiling of the first Bombardier Flexity 2 tramcar. Guests from Europe and further afield congregated in windy and overcast conditions at the south end of the promenade on September 8, where a new ten-road purpose-built depot has been built at Starr Gate especially for the new trams.

Celebrating its 125th anniversary last year, the tramway is one of the oldest electric tramways in the world, and Blackpool and Lancashire County Councils have ordered 16 of the trams at a cost of £33million.

The five section 32-metre long tramcars are built at Bombardier's Bautzen factory in Germany and also include contribution from the Vienna factory.

Councillor Simon Blackburn, Leader of Blackpool Council commented: "Providing a modern tram service that operates as an effective transport system while still offering visitors and residents the opportunity to enjoy uninterrupted views of our coastline is something unique to Blackpool. The new Flexity 2 model will help us improve access for people with prams or with wheel chairs for example and will run alongside our heritage trams.

As part of the introduction and commissioning process, the section of line from Pleasure Beach to Starr Gate is being used for testing and driver training purposes.

The Flexity 2 is an evolution from Flexity and other design of trams of which more than 3,500 are in service in 100 cities around the world, and Blackpool is the first customer for the second series. The second customer is the Gold Coast rapid transit project in Queensland, Australia, where 14 vehicles will be equipped with space for surf boards.

# RTSA SA CHAPTER NEWSLETTER

September 2011 Edition - High Speed Rail China



## 168 glitches mar China's high-speed rail



An internal report by China's ministry of railways has revealed the country's high-speed railways experienced 168 "glitches" in the month of July alone.

High-speed trains manufactured by CNR experienced the most problems, with the ministry's transport bureau identifying 56 malfunctions occurring on trains built by CNR's Changchun unit and a further 30 issues with trains built by the

company's Tangshan unit and a further 30 issues with trains built by the company's Tangshan unit.

106 out of the 168 issues were reportedly caused by "design and manufacturing quality problems". The report identified issues with trains built by four high-speed train manufacturers in total, including CSR, China Daily reported.

In August the Chinese Government announced that it would suspend approval of all new railway construction projects, slow down all of the country's high-speed trains and commence safety checks on its high-speed railways in the wake of the fatal high-speed train collision near the city of Wenzhou in July that killed 40 people and injured over 200.

The collision has raised major concerns around the globe over the country's fast-growing high-speed rail sector.



# RTSA SA CHAPTER NEWSLETTER

September 2011 Edition - International Rail Tourism



## Train travel around Taiwan touches foreign hearts



A group of railway fans from Australia, Japan and the U.K. said prior to their departure on Sunday that train travel around Taiwan has allowed them to find different reasons to fall in love with the island.

The 14-day trip is the first time that Taiwan worked with foreign travel agencies to present a train extravaganza to a multinational travel group, the Tourism Bureau said.

On Sept. 5, the 51 railway enthusiasts-- 12 British, 36 Australian and 3 Japanese -- met together at Taipei to experience a line-up of different trains in the country.

After using many networks, including the Taipei Mass Rapid Transit, Taiwan Railway Administration and the Taiwan High Speed Rail, the participants said they were amazed by the nation's railway system.

"We have been really impressed with the quality of the railways, not only the efficiency, punctuality but also how clean they are," said Stephen Martin, organiser of the British tour group. "They are much cleaner than in the U.K."

What added to the travel fun, said Australian group leader Owen Johnstone-Donnett, was the friendliness of local people.

During a ride on the Jiji Line, one of the country's historic branch railways, the group found themselves closely watched after by local people, who asked them constantly if they needed food, drinks or language services.

"It reminded me of the early days of train travel in Australia," he said. "It created a nostalgic and romantic experience that people go to the countryside and all of the local people are waving at you."

To rail fan Alison Shillington, it was a pleasant surprise along the journey that has bonded her to Taiwan.

When the group travelled to the Prisoner of War Memorial Wall in New Taipei City last week, the 75-year-old Australian unexpectedly found her father's name on it.

Captured by Japanese troops in Singapore during World War II, Shillington's father was interned in Taiwan between 1942 and 1944.

The deeply moving experience gave Shillington a chance to understand her father. She said he seldom spoke about his time as a prisoner but stated on many occasions that Taiwan was a beautiful country.

"It was an emotional moment for me," she said. "I was glad to learn that even at one of the hardest times in his life, my father managed to see the beauty of Taiwan."

# RTSA SA CHAPTER NEWSLETTER

September 2011 Edition - Last Months Presentation



## Near miss at Cootamundra

On the 1<sup>st</sup> September George Erdos gave a presentation on the ATSB investigation into the near miss at Cootamundra station between an XPT passenger train and stationary freight train.

George highlighted the methodology adopted by the ATSB for these types of investigation and demonstrated how that methodology is put into practice.

It was interesting to note that, although the investigation determined that a signalling system design error was the fault, it was a breakdown in the Quality Management System that was a major contributory factor into what may have been a very serious incident.

George also pointed out that the actions of the driver were commendable and these actions ensured that no incident took place.

The presentation is provided here for the benefit of those members who were unable to attend.





Australian Government

Australian Transport Safety Bureau



ATSB TRANSPORT SAFETY REPORT  
Rail Occurrence Investigation RO-2009-009  
Final

# Reported signal irregularity at Cootamundra NSW involving trains ST22 and 4MB7

12 November 2009

---

# 1 FACTUAL INFORMATION

---

## 1.1 Overview

At about 0217<sup>1</sup> on Thursday 12 November 2009 train ST22, an XPT passenger service, was being routed into No.1 Platform Road at Cootamundra, New South Wales. The driver of the XPT received a Medium Turnout<sup>2</sup> indication on signal CA74 signifying that the route into No.1 Platform Road was set and unobstructed. Shortly after passing over the Gundagai Road level crossing and traversing 136 points set reverse<sup>3</sup> the driver of the XPT observed the last wagon of freight train 4MB7, located on the Up Main line, was obstructing the path of his train. He applied the train brakes and stopped just short of train 4MB7 (Figure 1).

**Figure 1: Photograph taken from driving cab of XPT, with last wagon of 4MB7 in upper right**

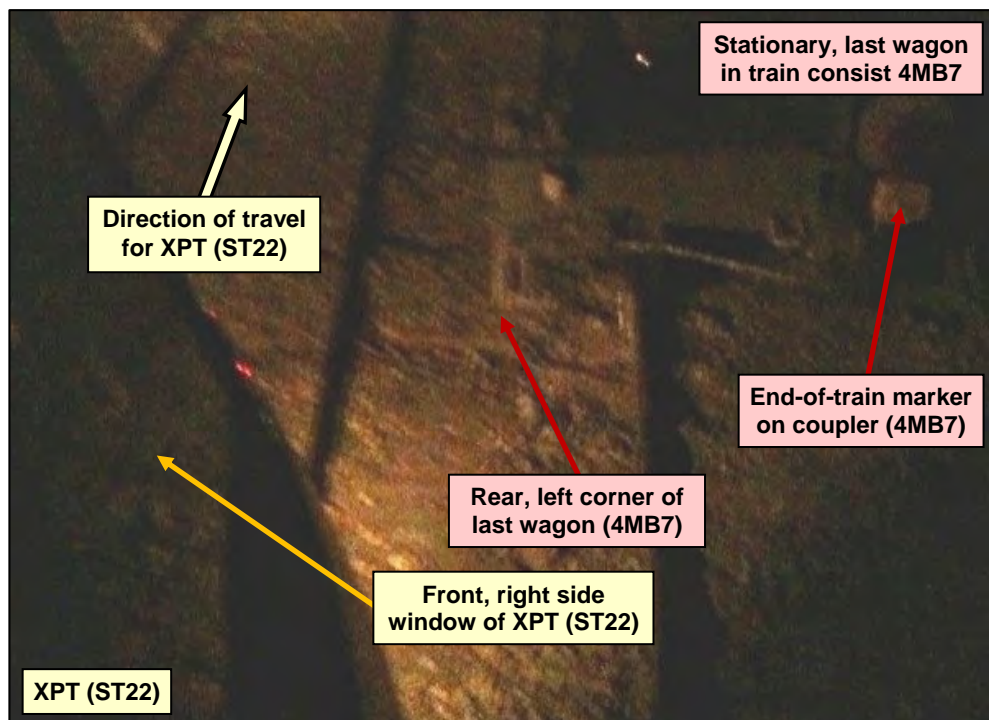

Copyright – Driver of ST22 ©

At the time of the incident, the temperature recorded at Young, about 40 km north-east of Cootamundra, was about 13 degrees Celsius. Wind was from the south-west blowing at about 7 km/h. The weather was fine and dry, visibility was good. However, at 0217 it was dark with the moon being well below the horizon. The driver of the XPT was therefore totally reliant upon his train headlight for external vision both ahead and peripherally.

---

<sup>3</sup> Normal Position - Lie of points defined by design, usually set for the main line.  
Reverse Position - Opposite to the normal position.

## 1.2 Location

Cootamundra is a regional centre (Figure 2) in mid-western New South Wales about 430 km by rail west of Sydney. The Cootamundra station/yard is located on the Melbourne to Sydney rail line and is part of the Defined Interstate Rail Network (DIRN).

Figure 2: Location of Cootamundra, New South Wales



Map - Geoscience Australia. Crown Copyright ©.

## 1.3 Train control

### 1.3.1 Cootamundra re-signalling project

On 4 June 2004 the Australian Rail Track Corporation (ARTC) signed an agreement with the New South Wales government to lease for a period of 60 years the New South Wales interstate and Hunter Valley rail corridors and was granted a licence to construct the Southern Sydney Freight Line within the existing rail corridor. Part of the lease agreement was a commitment that the ARTC would undertake a significant program of infrastructure improvement, including the replacement/upgrading of the manually operated signalling system at Cootamundra to facilitate remote control. As part of this upgrade, the train control function was consolidated into a network control centre located at Junee, New South Wales.

The ARTC infrastructure investment program was delivered through a 3 year Alliance arrangement<sup>4</sup> between the ARTC and their partners, John Holland Rail, MVM Rail and O'Donnell Griffin (ODG). The South Improvement Alliance (SIA) agreement was signed on 28 October 2005 and also included sub-alliance partners

<sup>4</sup> Alliance arrangement - A project delivery method whereby consortia of partners deliver a project. The consortia work together to define the scope, prepare the project budget, the program of works and then progress onto building the project.

Kellogg Brown and Root (KBR), GHD Pty Ltd, and CW-DC Pty Ltd who provided specialist design services to the prime-alliance partners.

Following the establishment of the SIA and formal sign off with the ARTC, a scope/outline for the Cootamundra re-signalling project was provided to SIA by the ARTC late in 2006. The SIA then developed a preliminary project brief, concept plan and associated cost estimates.

**Figure 3: Signal arrangement (part) - Cootamundra Yard**

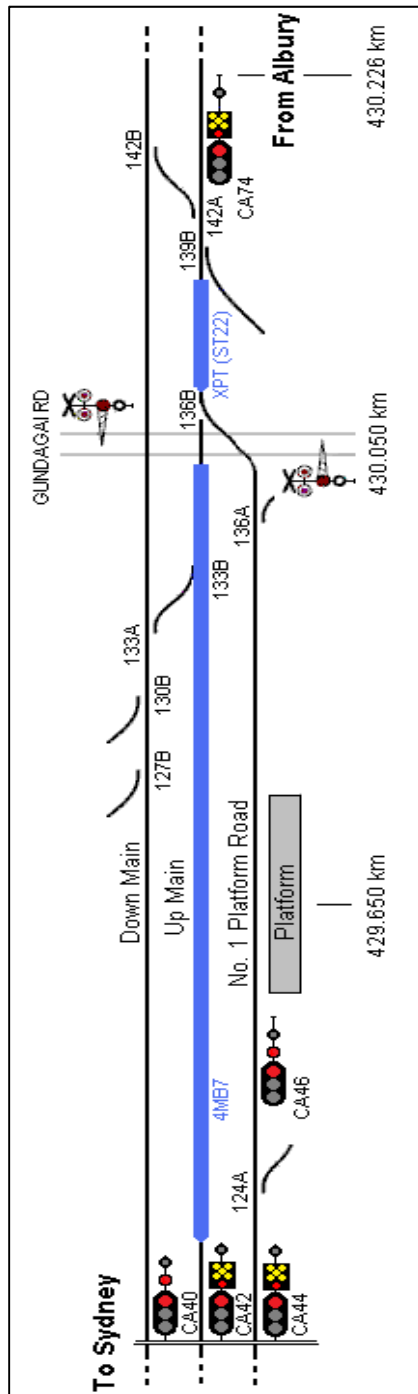

The plans and cost estimates were put forward and accepted by the ARTC early in February 2007. Following acceptance/sign-off by the ARTC, the SIA commenced the design phase before final onsite testing and commissioning. The design phase commenced in September 2006, with the final commissioning of the new signalling system at Cootamundra occurring during September/October 2007. The system had worked safely and reliably since that time.

**Cootamundra re-signalling – final system hardware**

Cootamundra Yard is controlled by fixed colour light signals using Rail Vehicle Detection (RVD)<sup>5</sup> and remotely operated from a network control centre located in Junee. For trains travelling from Albury towards Sydney, entrance onto No.1 Platform Road at Cootamundra (Figure 3) was over 136 points set reverse and controlled by signal CA74. Signal CA74 is located about 176 m on the Albury side of the Gundagai Road level crossing.

Line speed over 136 points set reverse is 25 km/h and increases to 100 km/h on the straight through No.1 Platform Road. However, all XPT services are scheduled to stop at Cootamundra and therefore the train speed usually remains relatively slow after passing over the points.

The hardware that makes up the signalling system at Cootamundra (Figure 4) substantially comprises:

<sup>5</sup> The portions of line where the system of Safeworking relies on track-circuiting or axle counters. (ARA Glossary for National Code of Practice and Dictionary of Railway Terminology)

**Figure 4: Diagrammatic representation of Cootamundra signalling system**

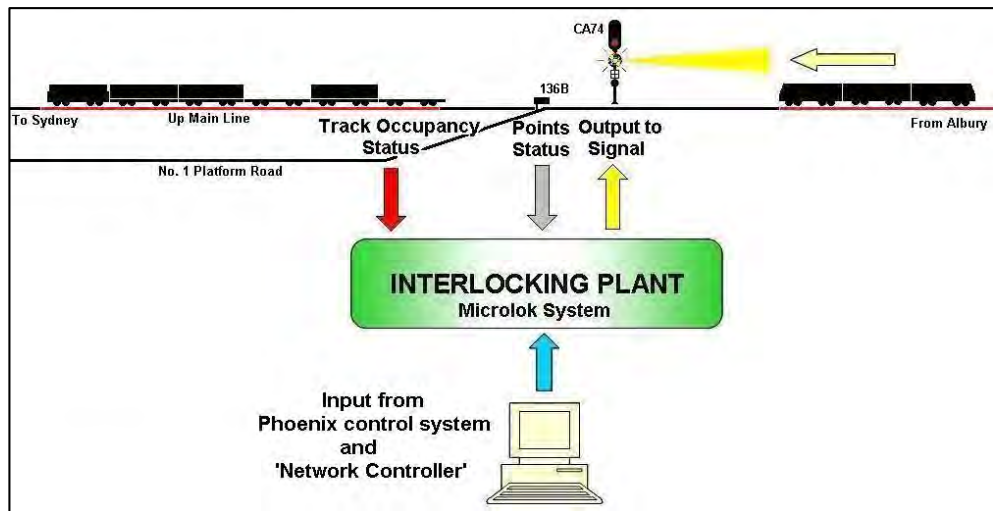

1. Field equipment: Items such as signals (Figure 5), points, track circuits, etc. These items of equipment feed information from the field into the interlocking plant (Microlok) and also provide a communication medium to train drivers, via the signals, so they are aware of the status of the track ahead.

**Figure 5: Typical items of field hardware – Signal CA74 and point machine 142B**



2. Interlocking Plant, Microlok system (Figure 6): Microlok is a proprietary microprocessor-based logic controller specifically designed for railway fail-safe<sup>6</sup> applications. The system provides all the necessary interlocking functions between points, signals and conflicting train routes. The system processes all the various field inputs and drives the outputs interfacing with designated field

<sup>6</sup> Fail-safe: The capability of an item or system to ensure that any failure in a predictable or specified mode will result only in that item or system reaching and remaining in a safe condition. (Source: Australian Standard AS4292 Part 4)

equipment while simultaneously maintaining a log of the various commands and the state of the input/output field equipment using an event logger.

Microlok incorporates two types of software program:

- The executive program, this is common to all Microlok systems and contains all the standard software applications that:
  - a. Ensure that all vital outputs are fully controlled.
  - b. Verifies the state of vital inputs and outputs.
  - c. Removes power to vital outputs in all cases where a system failure has occurred, thereby placing field equipment into a fail-safe mode.

The executive program is normally only changed/modified by the manufacturer of the Microlok system.

- The geographic application software is usually written by the railway owner or representative (contractor) and is specific to each signal layout. It is the software code that describes each specific signalling layout.

Geographic software/code and event logger data can be reviewed to assist with the examination of incidents, as was the case at Cootamundra.

**Figure 6: Typical Microlok relay room**



Copyright – Australian Rail Track Corporation ©

3. The Phoenix (Figure 7) control system: Is a non-vital<sup>7</sup> CTC<sup>8</sup> system that provides real time monitoring and control of field hardware including signals, points, track circuits and the associated management of train movements. Signal, points, track and train movement data is captured by the Phoenix event

---

<sup>7</sup> Non-vital: Signalling equipment and circuits are considered non-vital where failure to function correctly would not cause an unsafe outcome of the signalling system. Non-vital equipment and circuits do not affect the safe operation of the signalling system. (Source: Engineering Standard - NSW Signalling SGS 01 Infrastructure Engineering Manual –Glossary of Signalling Terms)

<sup>8</sup> Centralised Traffic Control (CTC): A safe working system of remotely controlling points and signals at a number of locations from a centralised control room. (Source: Glossary for the National Codes of Practice and Dictionary of Railway Terminology)

logger. This data can also be replayed to assist with the reconstruction of events and the examination of incidents.

**Figure 7: Graphics overview - Main South Board 'B', Phoenix Control System, Junee, New South Wales**

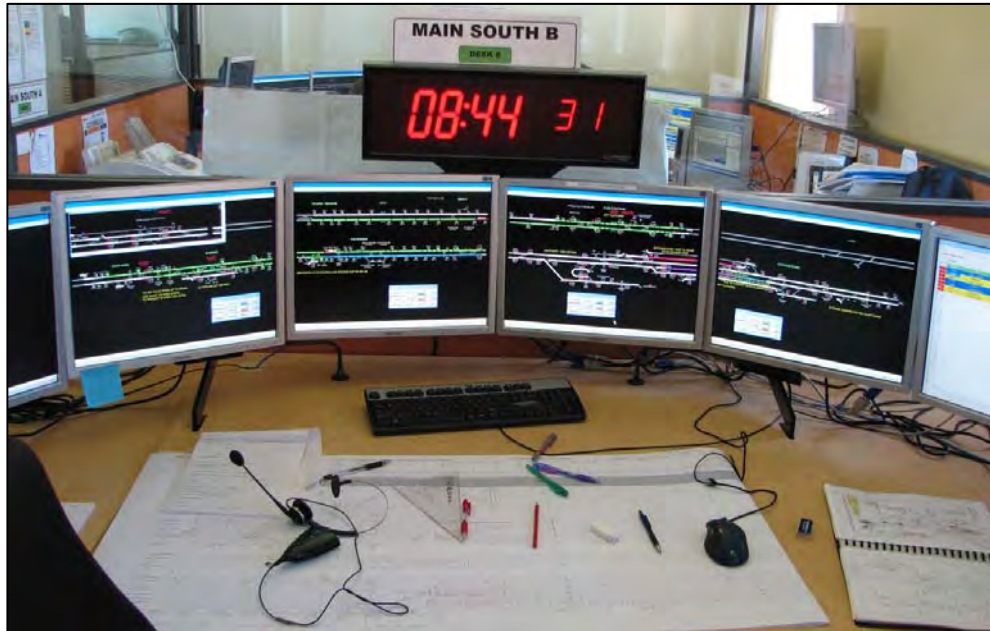

Copyright – Australian Rail Track Corporation ©

In railway systems employing colour light signals like those at Cootamundra the 'proceed authority' given to a train driver is provided by a group of coloured lights. The correct display and interpretation of these lights is essential for a train to be safely routed through a defined section of track.

At Cootamundra, signal CA74 controls a train entering into No.1 Platform Road from the Up Main line via points 136 set reverse. This signal provides turnout information and the status of the line ahead, that is whether the track is occupied or clear and whether the signal in advance (CA46) is displaying a stop or proceed<sup>9</sup> indication.

Figure 8 shows the signal sequence displayed to a train driver travelling from signal CA74 up to signal CA46 on No.1 Platform Road (points 136 set reverse). A Caution Turnout indication is displayed on signal CA74 when signal CA46 is at stop. A Medium Turnout indication is displayed on signal CA74 when signal CA46 displays a proceed indication (Caution, Medium or Clear). In each case, displaying a proceed indication on signal CA74 implies that the route up to signal CA46 will be unobstructed.

---

<sup>9</sup> Proceed Indication - Any signal indication other than stop. (Source: Engineering Standard - NSW Signalling SGS 01 Infrastructure Engineering Manual –Glossary of Signalling Terms).

Note: Throughout this report where 'Proceed Indication' is used it excludes signals used for shunting or low speed movements.

Figure 8: Signal sequence for signals CA74 and CA46

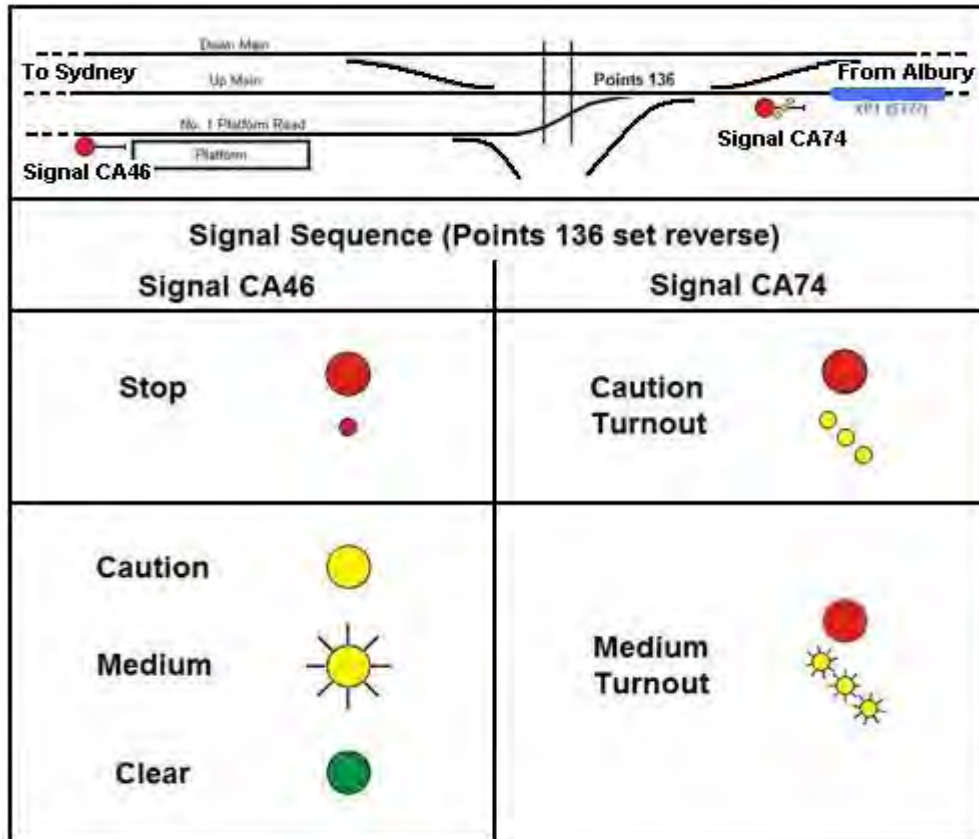

Note: The radial lines on the Medium and Medium Turnout indications imply that the lights are pulsating indications.

### 1.3.2 Junee network control centre

The passage of trains through Cootamundra was managed by one network controller operating off the Main South Board 'B' using ARTC's Phoenix control system located at Junee. Voice communication between train drivers and the network controller was by UHF radio.

#### **Network Controller**

The network controller involved with the incident commenced his employment with the New South Wales railways in 1997. During the period of his employment with the New South Wales railways he was engaged as area controller, with similar duties to that of a network controller, before moving over to the ARTC. He had been actively engaged by the ARTC as a network controller, for about 3 years, at the time of the incident. Evidence indicates that he was appropriately qualified, had extensive experience, was medically fit and signed on fit for duty.

## **1.4 Train details**

### **1.4.1 Train ST22 (XPT)**

Train ST22, the XPT, was a scheduled passenger service operated by RailCorp. It consisted of leading and trailing diesel power cars with six passenger carriages in between, including a buffet car.

The train was operated by a single driver and crewed by on board personnel. The train had an overall length of 178 m and a gross weight of 418 t.

The driver involved in the incident had in excess of 17 years experience. He commenced employment with the New South Wales railways in 1992 moving across to CityRail in 1997. During his service with CityRail he became qualified as a driver trainer and inspector. He joined CountryLink in 2006, was qualified to operate the Sydney to Melbourne route and had regularly driven the section of track where the incident occurred. At the time of the incident he was appropriately qualified, assessed as competent, had a good service history, was medically fit for duty and had signed on fit for duty.

### **1.4.2 Train 4MB7**

Train 4MB7 was operated by Interail Australia, a wholly owned subsidiary of QR. A driver and co-driver crewed train 4MB7. The train comprised two locomotives hauling 33 wagons with a total weight of 1507 t. The train had an overall length of 778 m including the locomotives. The drivers were appropriately qualified, had extensive experience and were in date medically.

## **1.5 The occurrence**

### ***Events on the day of the incident***

On the day preceding the incident, the XPT departed Melbourne's Southern Cross station at 2010, 15 minutes behind schedule. Arrival at Sydney Central was timetabled for 0655 the following day, 12 November. The train had engine problems on the trailing power car and was running slow as a result, causing further delays.

Train 4MB7 was scheduled to depart the South Dynon Yard, Melbourne at 1830 on 11 November 2009. It departed 38 minutes early but was 43 minutes late through Junee due to delays on route. The final destination for 4MB7 was Acacia Ridge outside Brisbane early on 13 November 2009.

The network controller on duty at the time of the incident signed on for duty at 2300. He was about 2 hours into his shift when both the XPT and train 4MB7 arrived at Junee. Fresh drivers for both trains signed on for duty (0050) to work the Sydney leg of their respective journeys.

Train 4MB7 departed Junee at 0116, about 17 minutes ahead of the XPT. It arrived outside Cootamundra just before 0204 and was routed onto the Up Main line, coming to a stand about 5 m in front of signal CA42.

The XPT departed Junee at 0133 (31 minutes late). The journey to Cootamundra was fairly uneventful except for a minor passenger disturbance, however, the trip was slow because the trailing power car was inoperative.

As the XPT approached Cootamundra the driver initially observed signal CA76, the signal before CA74, displaying a Caution indication (Figure 9). As the train neared signal CA76 it changed to a Medium (Figure 9) with the turnout repeater signifying that the train would be routed into No.1 Platform Road. At about this time the driver of train 4MB7, now stationary on the Up Main line, noticed that the adjacent Platform Road signal CA44 had cleared. This indicated to him that the following train, the XPT, had been given a through route to allow it to pass his train (Appendix B provides further information regarding the aspects that can be displayed by signals CA44, CA46, CA74 and CA76 at Cootamundra).

The XPT continued on its journey, as it rounded a left-hand curve the driver observed the next signal, CA74, displaying a Medium Turnout indication (Figure 9). He could simultaneously see signal CA46, located at the end of the Cootamundra platform, displaying a proceed indication. This indicated to him that the route through No.1 Platform Road was set but more importantly it should be unobstructed. As the driver of the XPT prepared to enter No.1 Platform Road he slowed the train to a speed of about 25 km/h to negotiate 136 points, set reverse. It was at about this time he observed the ‘End of Train Marker’ (flashing red light) fitted to the last wagon of freight train 4MB7. The XPT driver continued to slow the train as he approached train 4MB7. When the XPT was near the Gundagai Road level crossing (430.050 km) the driver could clearly see the last wagon of train 4MB7 illuminated by his train’s headlights. He continued to drive slowly towards train 4MB7. Shortly after passing over the Gundagai Road level crossing and traversing 136 points he became sure that train 4MB7 was ‘foul’ and would obstruct the passage of his train. He further slowed the XPT stopping it about 5 m short of train 4MB7.

**Figure 9: Signal CA74 & CA76 – Signal indications**

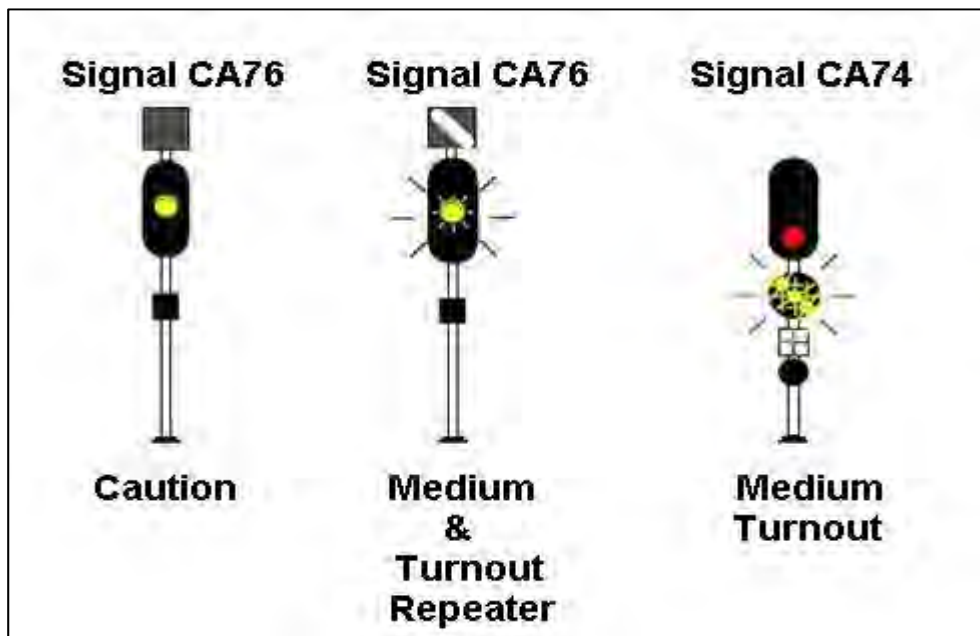

Note: The radial lines on the Medium and Medium Turnout indications imply that the lights are pulsating indications.

After coming to a stand the driver of the XPT contacted the network controller on the Country Net radio system. He advised the network controller of the problem and requested that train 4MB7 be moved forward as it was obstructing the path of his train. After some initial confusion, the network controller contacted the driver of train 4MB7 who was asked to move his train forward.

The driver of train 4MB7 then powered his locomotive and moved the train forward approximately 5 m bringing the lead locomotive almost directly under signal CA42. At 0228 the driver of the XPT contacted the network controller to advise him that freight train 4MB7 now appeared clear and was no longer fouling the path of the XPT. Following on from this advice, the network controller authorised the driver of the XPT to continue towards Cootamundra.

After stopping at Cootamundra station the XPT continued on its journey towards Sydney. During the early part of this onward journey, the XPT driver contacted the ARTC operations manager requesting that the incident be investigated, however due to the unusual nature of this failure (i.e. the Phoenix screen showed no anomaly) it was not recognised by the network controller on duty at the time of the incident nor the ARTC operations manager as being a wrong side failure.

### ***Post occurrence***

At about 0740 that morning, two ARTC signal engineers were advised of the incident and requested to investigate. Following a review of the Phoenix replay files and an onsite inspection at Cootamundra, they reported that they had identified that a signalling irregularity allowed CA74 to be cleared for the passage of the XPT even though the route was fouled by the last wagon of train 4MB7. It was only at this time the incident was recognised as a wrong side failure and an appropriate technical response was initiated. The ARTC placed an immediate prohibition on all similar movements and commenced a full investigation. The ARTC has advised that following this incident, briefings were held with Train Transit Managers and network controllers to ensure that wrong side failures and signal system anomalies either observed in the Control Centre or reported by operators or maintainers are managed in accordance with established ARTC procedures and in a timely manner.

### ***Loss and damage***

There were no reported injuries and/or associated loss or damage to any rolling stock or infrastructure as a result of the incident.

At 0835 on 12 November 2009 the Australian Transport Safety Bureau (ATSB) received notification of a reported signal irregularity, involving the XPT and train 4MB7 at Cootamundra, from the New South Wales Office of Transport Safety Investigations (OTSI). The ATSB commenced an investigation into the incident.

The investigation initially concentrated on the preservation of perishable evidence including: the Microlok data files, Phoenix data files, train data logs, site photographs and site measurements/other information. Evidence was subsequently supplemented with information sourced from the ARTC, the crew of the XPT and train 4MB7, RailCorp and the South Improvement Alliance (SIA).

Evidence included interviews, photographs, train running information, voice and data logs, engineering documentation, site plans/circuits and safety policies/procedures.

Based on an initial review of available evidence, it was concluded that:

- There were no mechanical deficiencies with either train 4MB7 or the XPT<sup>10</sup> which would have contributed to the incident.
- There were no deficiencies in track condition that would have contributed to the incident.
- Analysis of the data logs from the XPT and 4MB7 established that both trains were managed and driven in an appropriate manner. The actions of the train drivers in the handling of their respective trains did not contribute to the incident. The crews were appropriately trained, qualified and fit-for-duty at the time of the incident. There were no crew performance issues that would have contributed to the incident. In fact the vigilance of the XPT driver was noteworthy in that his actions were instrumental in avoiding a collision.
- A signalling system design error was identified as the primary factor giving rise to the signal irregularity. This design error allowed signal CA74 to be cleared for the passage of the XPT even though the route was fouled by the last wagon of train 4MB7.

The purpose of a rail signalling system is to facilitate the safe and efficient movement of rail passengers and freight services. Railway signalling systems have evolved from manually operated mechanisms through to advanced computer based safety systems that interface with state of the art electronic control technologies. In common though, all of these systems enshrine underlying safety principles (namely the necessary interlocking between points, signals and conflicting train routes) that allow trains to run safely and efficiently over a defined section of track.

In this case, events appeared to indicate that trains, 4MB7 and the XPT, were at risk of collision, even though all train movements were made under signal indication. The balance of the report therefore will focus on the analysis process used to identify the signal system irregularity, followed by an examination of the systemic processes that allowed the irregularity to occur.

---

<sup>10</sup> Excludes the failure of the trailing power car, a known mechanical fault on the day, but in no way a factor that would have contributed to the signal irregularity.

## 2.1 Sequence of events analysis

### Day of the incident

The following reconstruction of events for 12 November 2009 is based on a combination of interviews with the train crews (4MB7 and the XPT), an examination of the train data logs, the Phoenix replay files (Figure 10 to 18 hereunder), Microlok data, and evidence sourced from the ARTC signal engineering staff.

Freight train 4MB7 departed Junee (Albury side of Cootamundra) at 0116 and arrived outside Cootamundra about 0204. It was routed onto the Up Main line to facilitate the passing of passenger service ST22 (XPT) using No.1 Passenger Road.

Figure 10: Cootamundra, Phoenix replay 0213:14

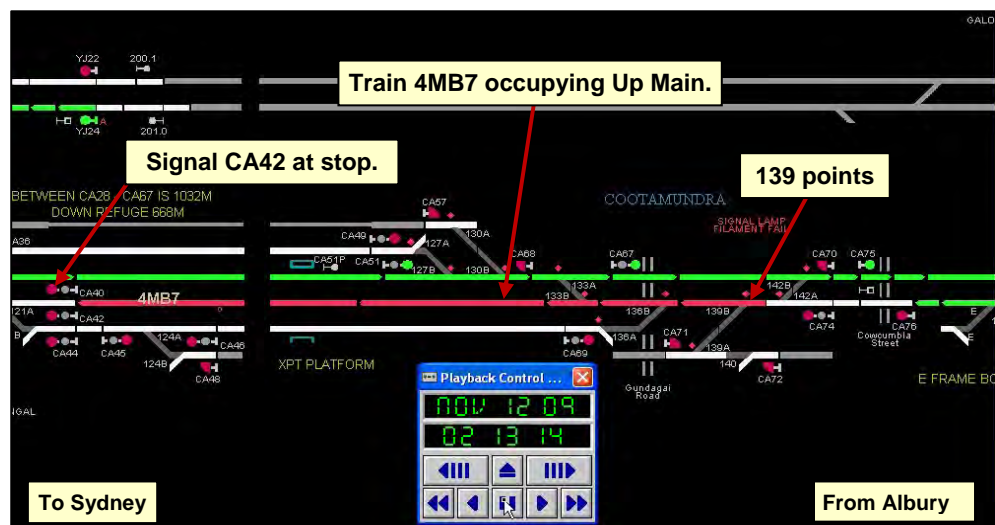

Copyright – Australian Rail Track Corporation ©

The Phoenix replay, Figure 10 (0213:14), shows train 4MB7 occupying the Up Main (signal CA42 at stop) with the end of train traversing 139 points set normal.

Figure 11: Cootamundra, Phoenix replay 0213:47

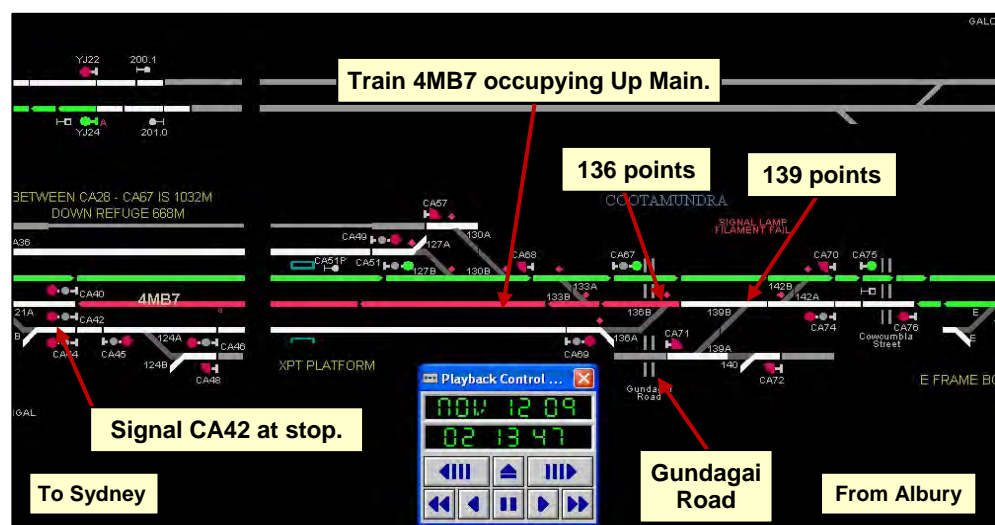

Copyright – Australian Rail Track Corporation ©

Figure 11 (0213:47) shows that train 4MB7 has cleared 139 points but is still traversing 136 points (set normal) and the Gundagai Road level crossing.

**Figure 12: Cootamundra, Phoenix replay 0214:16**

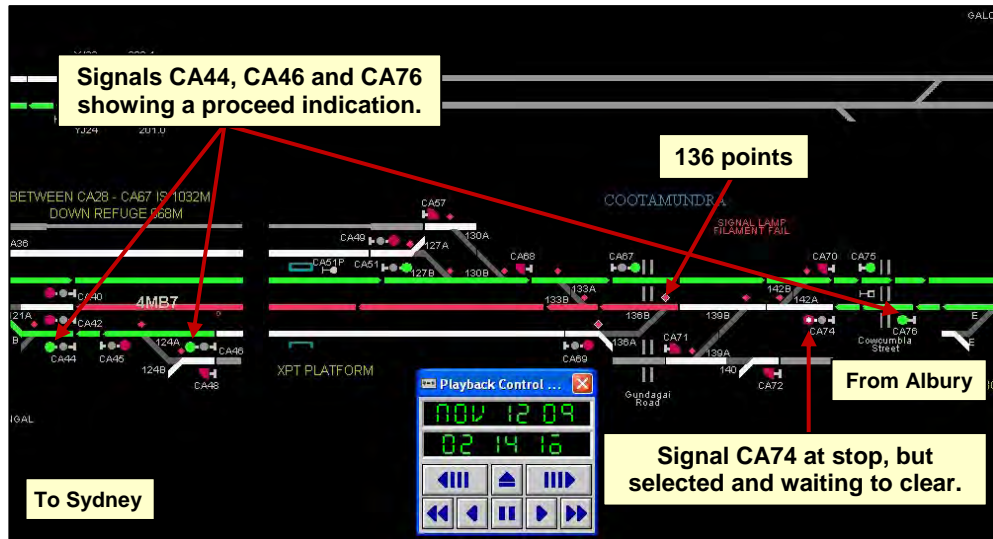

Copyright – Australian Rail Track Corporation ©

Figure 12 (0214:16) shows signals CA44, CA46 and CA76 have cleared and are displaying a proceed indication. Signal CA74 is still at stop, but has been selected and is waiting<sup>11</sup> for route availability before it can clear. An examination of events just after 0214:16 established that train 4MB7 was travelling slowly towards signal CA42 with the end of train traversing 136 points and the Gundagai Road level crossing. Signal CA44 clearing is corroborated by evidence given by the driver of train 4MB7, he stated that he noticed that the Platform Road signal CA44 had cleared for the passage of the XPT (ST22).

**Figure 13: Cootamundra, Phoenix replay 0214:49**

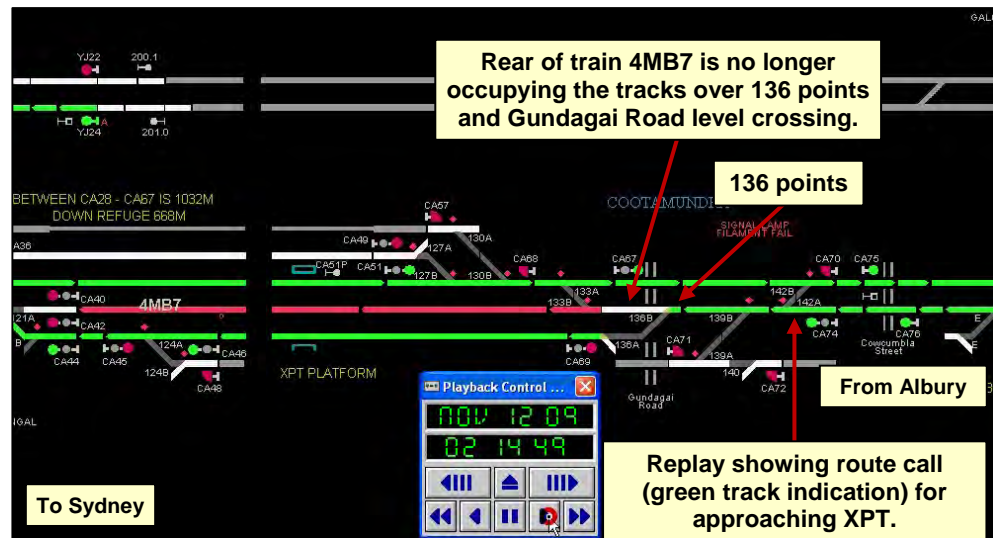

Copyright – Australian Rail Track Corporation ©

<sup>11</sup> Signal CA74 will automatically clear when the route being traversed by 4MB7 becomes available, i.e. the signalling system sees the route from CA74 to CA46 as being unobstructed.

Figure 13 (0214:49) shows the rear of train 4MB7 having just cleared 136 points and the Gundagai Road level crossing. An examination of events at this time shows signal CA74 clearing when the rear of freight train 4MB7 had completely traversed 136 points and the Gundagai Road level crossing.

Figure 14: Phoenix replay 0215:01

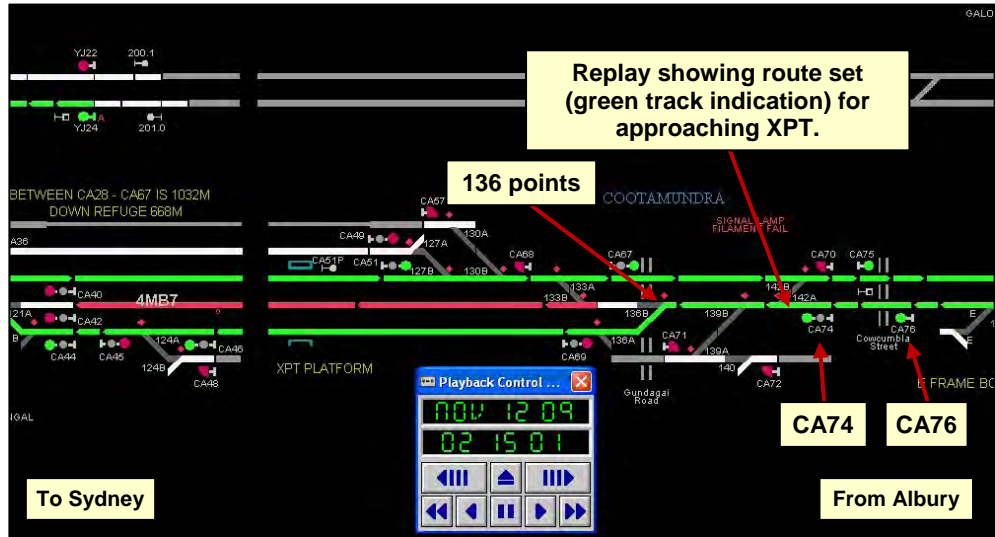

Copyright – Australian Rail Track Corporation ©

Figure 14 (0215:01) shows train 4MB7 at stop<sup>12</sup> on the Up Main line and clear of 136 points and the Gundagai Road level crossing. Signals CA76 and CA74 are displaying a proceed indication for the XPT. The network controller and XPT driver would rightly expect that the route for the XPT into No.1 Platform Road was set and unobstructed.

Figure 15: Phoenix replay 0216:14

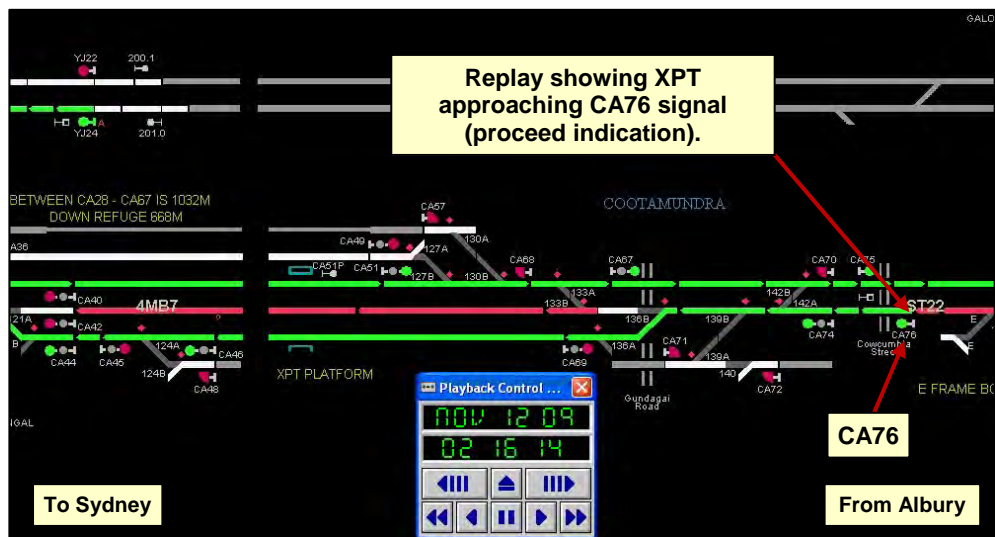

Copyright – Australian Rail Track Corporation ©

<sup>12</sup> Independently corroborated by data recorded on lead locomotive LDP9 of train 4MB7.

Figure 15 (0216:14) shows the XPT occupying the track in advance of signal CA76 which is displaying a proceed indication. The train was travelling at a speed of about 77 km/h (XPT Hasler data log) as it passed signal CA76.

**Figure 16: Phoenix replay 0217:01**

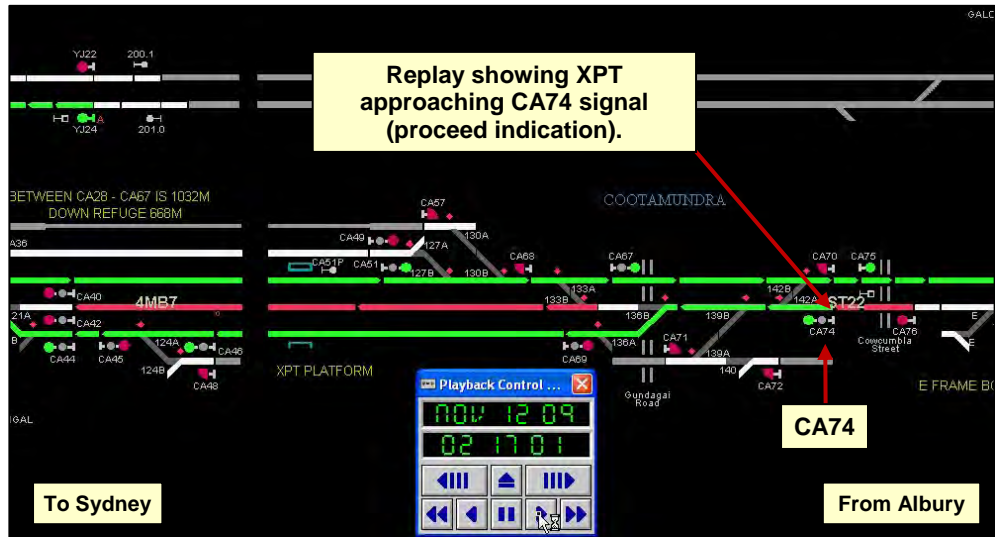

Copyright – Australian Rail Track Corporation ©

Figure 16 (0217:01) shows the XPT occupying the track in advance of signal CA74. Signal CA74 is displaying a proceed indication. The train had slowed to about 50 km/h (XPT Hasler data log) as it passed signal CA74. To the driver of the XPT, signal CA74 displaying a Medium Turnout indication would mean the route ahead was correctly set and unobstructed.

**Figure 17: Phoenix replay 0217:35**

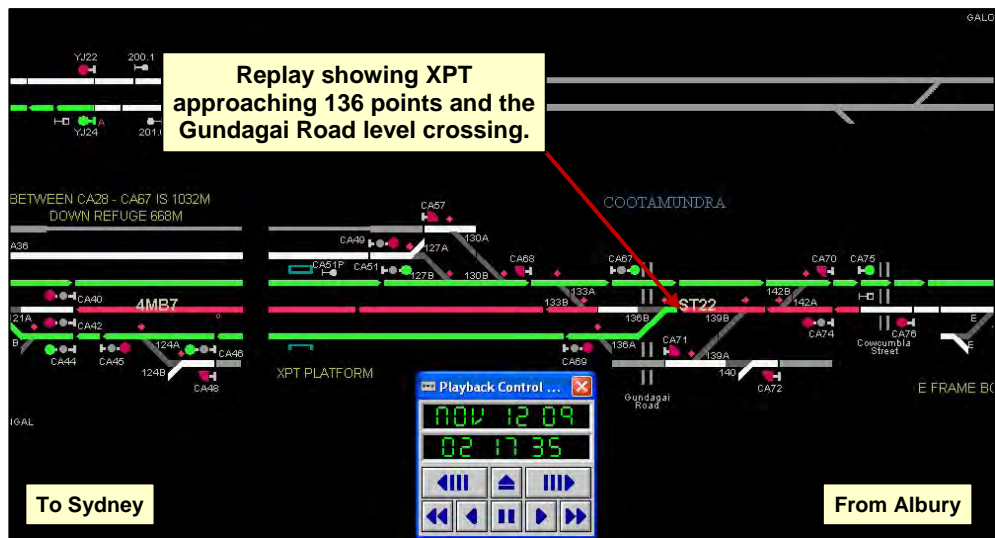

Copyright – Australian Rail Track Corporation ©

Figure 17 (0217:35) shows the XPT occupying the track in advance of 136 points and the Gundagai Road level crossing. As the driver of the XPT prepared to enter No.1 Platform Road he had further slowed the train and was travelling at less than 20 km/h (XPT Hasler data log) before negotiating 136 points (set reverse). It was at

about this time he observed the ‘End of Train Marker’ (flashing red light) fitted to the last wagon of freight train 4MB7.

**Figure 18: Phoenix replay 0217:36**

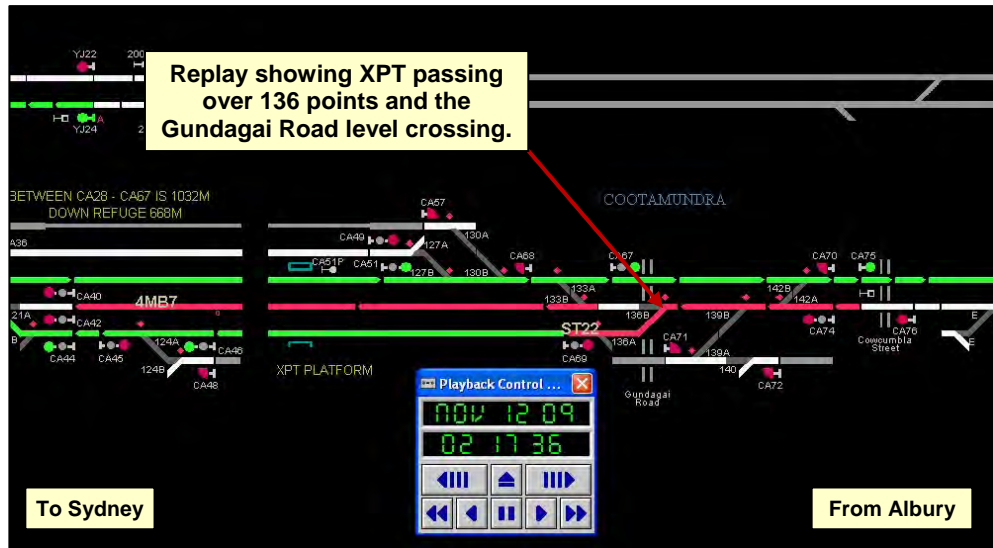

Copyright – Australian Rail Track Corporation ©

Figure 18 (0217:36) shows the XPT occupying the tracks located over 136 points and the Gundagai Road level crossing. It was about this time that the driver of the XPT became sure that 4MB7 was standing ‘foul’ and would obstruct the passage of his train. He further slowed the train, stopping it about 5 m short of 4MB7 before alighting from the driver’s cab to take some photographs (Figure 19).

**Figure 19: Photograph A – View from XPT drivers cab, looking towards the last wagon of 4MB7 seen in upper right.  
Photograph B – XPT driver standing adjacent to step of last wagon of 4MB7, looking towards XPT, glare of headlight in background**

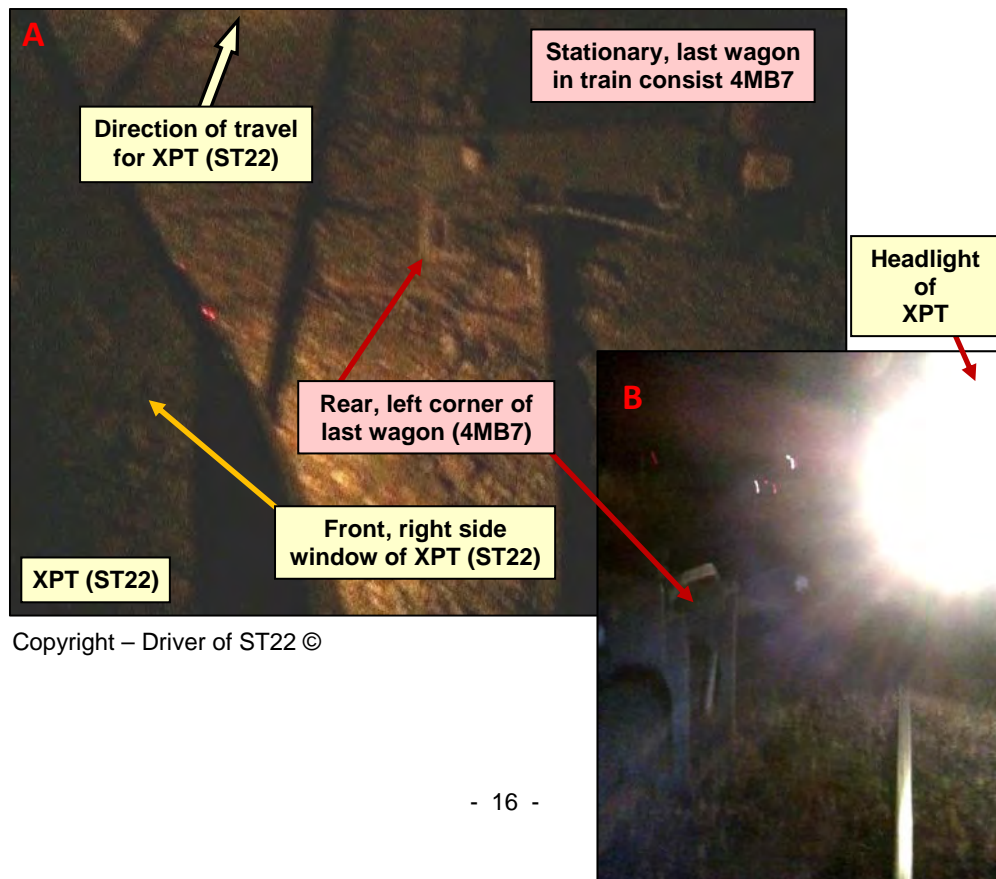

Copyright – Driver of ST22 ©

At about this time the driver of the XPT contacted the network controller, advised him of the problem and requested that 4MB7 be moved forward so that the XPT could advance into No.1 Platform Road. Train 4MB7 was subsequently driven forward approximately 5 m which allowed the XPT to advance safely into No.1 Platform Road.

The photographs at Figure 19 and schematic at Figure 20 illustrate the close clearances the XPT driver observed, why he brought his train to a stand and then requested that the matter be investigated.

**Figure 20: Schematic showing incident site and 4MB7 and XPT**

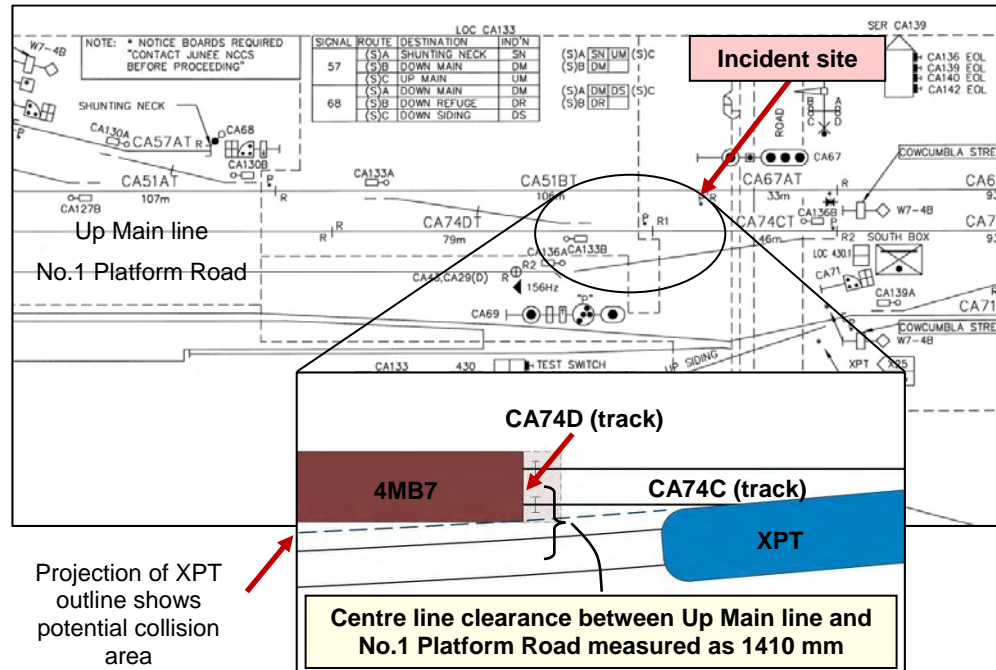

Later that morning, ARTC signal engineers used the Phoenix replay file to examine the events leading up to the incident. This was followed by a review of the signalling control tables which established that the insulated joint interface between CA74D track and CA74C track (Figure 20 and Figure 21) was designed as the clearance point for a train movement from CA74 to CA42 signal. This meant that when the wheels of 4MB7 had passed the clearance point (the insulated joint between CA74D and CA42C track circuits) the signalling system allowed the alternative route, namely, CA74 to CA46 signal to become available for the XPT.

On this occasion, train 4MB7 stopped such that the rear wagon was about 0.5 m past the clearance point. However, when considering the overhang of the last wagon past the rear wheels, it is possible that the wagon could have been about 2 to 3 m further back and not been detected by CA74C track. This meant that signal CA74 would have shown a proceed aspect even if the rear of train 4MB7 was 2 to 3 m further fouling of the path of the XPT.

An onsite examination of the track by the ARTC signal engineers established that the centre line clearance between the Up Main line and No.1 Platform Road at the interface between CA74D and CA74C track was 1410 mm. The ARTC subsequently advised that the minimum distance to prevent fouling between the two tracks at this location should have been 2016 mm.

**Figure 21: Photograph adjacent CA74D and CA74C tracks**

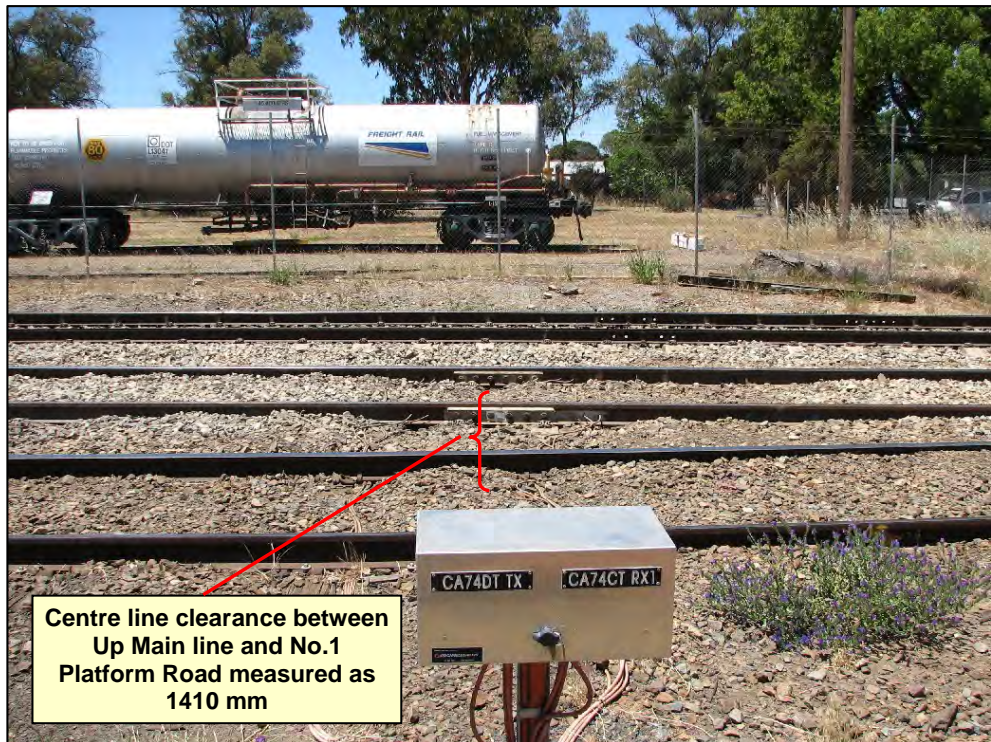

It was therefore concluded that the observations by the driver of the XPT were correct, in that the rear of 4MB7 was obstructing the path of the XPT even though signal CA74 was showing a proceed indication.

The cause of the irregularity was identified as a signalling design error. As a result, the ARTC placed an immediate prohibition (pending resolution) on the use of all signalled routes from CA74 into No.1 Platform Road when the Up Main was occupied. The ARTC also instigated an immediate review of all clearance points on recently re-signalled crossing loops and refuge loops throughout NSW.

### **2.1.2 Overview - signalling design process**

Bringing a new signalling system into operation is a highly complex and resource intensive process with successful delivery being heavily dependent on the competence of signal engineers/technicians and associated personnel. The work is manually intensive and to provide for the highest levels of integrity all processes are subject to independent check, validation, approval and testing against mandated signalling principles.

However, the processes are open to human error and the incorrect application or interpretation of signalling principles and/or a break down in quality control processes can result in unintended errors that can affect the safety of train movements.

The flowchart in Figure 22, for Cootamundra, illustrates some of the elements involved in this work and is further described in the associated dot points:

Figure 22: Flowchart design processes for Cootamundra re-signalling

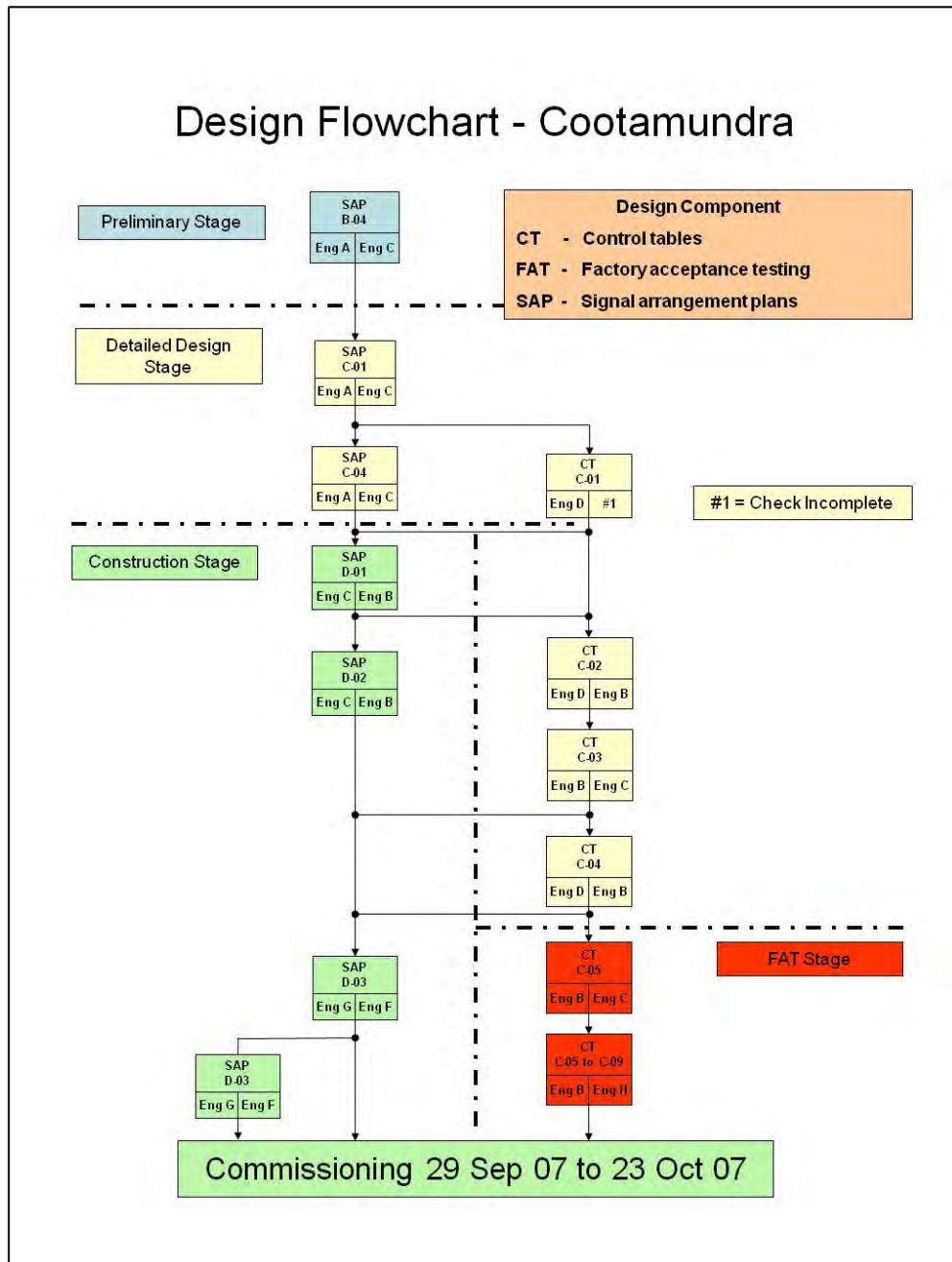

- The ‘Signalling Arrangement Plan’ is a schematic<sup>13</sup> (Figure 23) showing all signalling infrastructure associated with the physical track layout.
- ‘Control Tables’ define points, signal and level crossing interlocking logic. A simplified signal arrangement plan and the control table relevant to the area of interest at Cootamundra are illustrated at Figure 24.

<sup>13</sup> The plan is normally drawn to a horizontal scale, i.e. longitudinal scale along the length of the track. The plan may or may not have a vertical scale, i.e. the width of the track. If a vertical scale is provided it will often be of a different scaling factor than the horizontal scale.



Figure 24: Cootamundra - Simplified signalling arrangement plan and control table

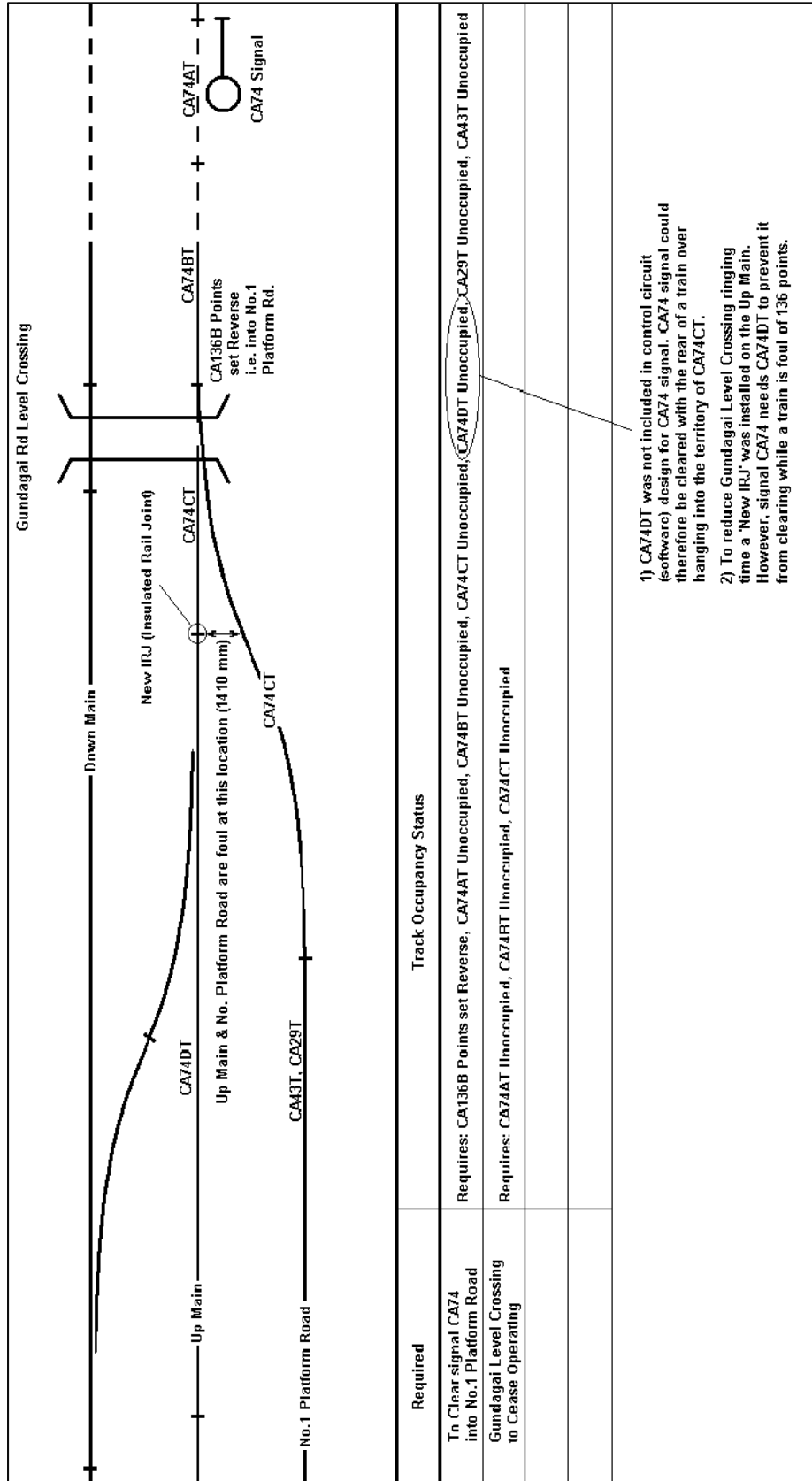

### 2.1.3 Review of actual signalling design process

The investigation established that the ARTC held regular management meetings with the South Improvement Alliance (SIA) but only provided them with limited technical guidance<sup>14</sup>. The ARTC advised that it was not resourced to undertake the detailed checking of signalling arrangement plans, control tables and/or signalling designs, nor was it resourced to undertake the testing or commissioning phases of the project. The ARTC considered that through the alliance agreement with the SIA it had structured an arrangement which meant that the SIA was primarily responsible for the delivery of an operationally safe signalling system with minimum ARTC input.

The SIA signalling design process was next examined and considered to be fairly conventional, in that the signalling arrangement plan was substantially finalised, before the development of the control tables. The original/old signalling arrangement for Cootamundra (mechanical interlocking plan, circuit plans, etc) were supplied to the SIA and used as a basis for designing the new signalling scheme. Minimal changes were made to the new scheme, the only notable variation was the provision of an automatically controlled level crossing at Gundagai Road.

Data design, factory and onsite testing generally followed control table development. However, as the project neared completion it became necessary to undertake control table and software development concurrently to meet the targeted commissioning date. Normally control table and software development is done sequentially to ensure that all the control table logic is fully reflected in the final software and associated validation/testing processes.

It was evident from interviews with the designing engineers that they believed the tight project time frame compromised the normal testing process and probably limited their ability to identify potential errors.

#### ***Signal design staff***

SIA had 10 signalling engineers involved in the design and commissioning of the Cootamundra re-signalling scheme. All had extensive experience (in excess of 20 years) and were regarded as highly competent in the field of railway signalling.

The initial selection of signal designers and checkers was based on ability and competence to do the work; checkers were further required to demonstrate extensive design/checking experience. During the execution of the project it became necessary to substitute various designers and checkers due to non availability of some SIA staff. Substitution was done on the basis of ability/competence and also capacity to ensure best knowledge transfer, thereby maintaining project continuity.

In addition to the engineers, a senior site manager was engaged to audit and manage the on-site railway signalling works. He had about 42 years signalling experience working as a signal technician, test room maintenance manager, district and maintenance supervisor.

The investigation established that the signal designers and checkers used by the SIA for the Cootamundra signalling project had extensive experience and were used in

---

<sup>14</sup> Technical guidance occurred at the initial/concept phase of the project, in particular it involved the validation of the signalling arrangement plan and the risk definition/assessment phases.

such a way as to ensure best available experience and greatest opportunity for project continuity.

### ***Identification of clearance points***

The ARTC New South Wales Engineering Standard for 'Inspection and Testing of New and Altered Signalling Works – General Requirements' Reference Number SCP 08 – (RIC Standard: SC 00 41 02 00 SP) at Section 3.1.4 'Clearances and Positional Relationships' requires the examination of infrastructure to:

Ensure that structure gauge clearances, train stop gauging etc, and positional relationships between apparatus, e.g. signal/train stop/blockjoint, are included as part of the certification inspection to the Track Plan, Working Sketch, and Track Insulation Plan.

With the introduction of automatic level crossing operation at Gundagai Road, the original track circuit over CA133 points to CA136 points was split into two and became CA74C and CA74D tracks. This was done to minimise the level crossing ringing time. With no information shown on the signalling arrangement plan<sup>15</sup> the joint between CA74C track and CA74D track was incorrectly used as the clearance point for signalled moves from CA74 signal into No.1 Platform Road. Figure 24, shows a simplified control table and signalling arrangement plan at the point of interest. It can be noted that the inclusion of CA74D track into the logic code for signal CA74 prevents it from clearing until CA74D track section is unobstructed.

Although SCP 08 at Section 3.1.4 requires that clearances and positional relationships are identified, the designing engineers did not have a good appreciation of the site geography at Cootamundra. Had they been aware that the interface between CA74C and CA74D was at a fouling point between the Up Main line and No.1 Platform Road they would have certainly included CA74D track in the original design logic. It is therefore possible that greater local knowledge and/or the involvement of the ARTC (with local knowledge of the site geography and layout) during the design and commissioning phases may have assisted the SIA in detecting the design error. Alternatively if there had have been a systematic recording of the clearance point in the Signal Arrangement Plan, Track Insulation Plan or Control Tables then site testing or other verification activities would have probably identified the mistake.

When the issue was eventually identified by some of the SIA designing engineers their concerns were not effectively recorded on plans or associated documentation (see Quality control process) which meant that the issue was easily overlooked during all subsequent phases of the project.

In conclusion, had the SIA engineers effectively identified and recorded that the interface between CA74C and CA74D was the fouling point between the Up Main line and No.1 Platform Road they would have recognised that the rear of a train sitting on the Up Main line at this location would foul No.1 Platform Road.

### ***Design philosophy***

It was drawn to the attention of investigators that during the preparation of the control tables and in the absence of adequate information on the signalling

---

<sup>15</sup> The centre-line distance between the Up Main line and No.1 Platform Road at this location had not been checked and as part of the investigation was found to be 1410 mm and therefore foul.

arrangement plan, it would have been prudent for the designers to have included both CA74C and CA74D as the clearance tracks. Without having checked the site for actual clearances this would have at least meant the new signalling design would have reflected the original/old design in that signal CA74 would not have cleared until both CA74C and CA74D were unobstructed.

A design based on using a clearance point at the interface of CA74C and CA74D should not have been implemented until it was established that the clearance between the Up Main line and No.1 Platform Road at the interface of CA74C and CA74D tracks was adequate.

### ***Quality control process***

To mitigate the risk of errors arising during the development of complex engineering systems, organisations involved in their development, generally use quality control processes to track all design, testing and commissioning events. The quality processes specifically formalise checking and validation processes and thereby limit the chance of unintended errors. They also provide an audit trail in the event that an error is detected.

Throughout the project test logs were raised by SIA staff for recording any design issues identified (errors, omissions, items that required clarification, etc). Adjustments to the signal arrangement plan and control tables were then undertaken as necessary and when suitably resolved, the issue was closed off. At the commencement of the project, SIA staff used a simple quality control process to manage identified design issues. This comprised annotating the original signal arrangement plan/control table, etc with a note regarding the identified issue. The signal arrangement plan/control table was then sent to the original designer to correct or explain the identified issue. When the issue was suitably explained or corrected to the satisfaction of the checker, this was acknowledged and signed off on the original signal arrangement plan/control table. This process was subsequently enhanced by recording the information within a test log database, not just on the signal arrangement plan/control table. This enhanced quality control process allowed for the accurate explanation and tracking of all identified issues. However, this enhanced quality control process was only implemented towards the end of the Train Control Consolidation<sup>16</sup> (TCC) project; it was not used at the time of re-signalling Cootamundra.

During the early phase of the Cootamundra design process at least one engineer had questioned whether the interface between CA74C and CA74D track was the clearance point. He stated that he had recorded this on a copy of his signalling arrangement plan, stating that the matter required further checking. However, the documentation to support this claim could not be produced. Clearly the issue had not been closed out and therefore raises concerns about the integrity of the SIA quality control process at that time.

A second engineer, involved in a later checking phase, also indicated that he had identified that there may have been a clearance problem at the interface of CA74C and CA74D tracks. He raised a query accordingly. However, the query was only recorded on the original copy of his control table and had not been closed out. Once

---

<sup>16</sup> Train Control Consolidation was the project implemented by the ARTC to fully automate signalling and train control functions on the NSW interstate rail network.

again, the integrity of the quality control process used by SIA at the time must be questioned.

While interviewing the co-ordinating Project Manager he indicated that as the TCC project progressed, the SIA themselves identified a need to enhance the quality control process. It was subsequently enhanced to ensure that identified design issues were effectively captured and tracked through to closed-out. He further advised that the new quality control processes could not be applied retrospectively to projects that had been completed, like Cootamundra, as it was not possible to recreate all the underlying steps involved in the documentation process.

In conclusion it was found that the documentation and quality control processes used by the South Improvement Alliance for the Cootamundra re-signalling project were not robust, in particular with respect to the recording, investigation and closing out of identified design issues. It is quite likely that had an enhanced quality control process been in place at the time the Cootamundra signalling scheme was designed that the clearance issue at the interface of CA74C and CA74D tracks would not have been overlooked.

### ***Onsite testing phase***

The ARTC test procedures, New South Wales Engineering Standard for 'Inspection & Testing of New & Altered Signalling Works – Typical Inspections & Tests for Signalling Apparatus' Reference Number SCP 10 – (RIC Standard SC 00 41 02 02 Version 2.0)' at Section 5.1 'Track Circuit Apparatus Inspection' mandates a requirement to:

Check length and limits of track circuit, position of insulated joints, fouling point clearance, point and other insulations, traction bonds, electrolysis bonds.  
Check polarity of each rail of D.C. track circuits and Impulse track circuits is as shown on the Track Insulation Plan.

There are many occasions during a signal commissioning process where using a highly skilled signal engineer is not warranted. For example, some elements of the onsite testing phase simply require an audit of field equipment against the signalling arrangement plan.

At Cootamundra this work was completed by the senior site manager (on this occasion not the designing engineer). However, without knowledge of the underlying interlocking principles it was not possible for him to recognise that the interface between CA74C and CA74D tracks was the clearance point for a signalled move from CA74 signal into No.1 Platform Road. Had the information been appropriately recorded on the Signal Arrangement Plan, Track Insulation Plan or shown in the Control Tables and a specific tester's note been promulgated, checking for fouling point clearance at this location would have been obvious.

In this case, if the field tester was required to validate the centre line clearance between the Up Main line and No.1 Platform Road at the interface of CA74C and CA74D tracks was not less than 2016 mm, this should have been documented. It was evident through discussions with the senior site manager that he was unaware of a need to check the centre line clearance between the Up Main line and No.1 Platform Road at the interface of CA74C and CA74D tracks and therefore did not do it.

Clearly, where a signalling design has implicit safety requirements that need to be validated onsite, field testers should either be provided with comprehensive check

notes and/or clearly annotated information that ensures specific testing requirements are not omitted.

Where a design involves complex signalling arrangements, it may be beneficial to involve the designing engineer during the final onsite field testing phase as they have the best understanding of the interlocking principles. This places them in a strong position to identify any design omissions or deficiencies that may not have been evident during earlier phases of the project.

If the senior site manager had had sufficient information during the onsite testing he probably would have identified that there was a problem with the centreline clearance between the Up Main line and No.1 Platform Road at the interface of CA74C and CA74D. Similarly, had the design engineer been involved in the on-site testing it is likely that he would have identified that the interface between CA74C and CA74D should not have been used as the clearance point for a signalled move from CA74 signal to No.1 Platform Road.

## **2.2 Safety action taken**

On the morning of 12 November 2009 the ARTC advised that they had undertaken a preliminary investigation into the reported signalling irregularity at Cootamundra involving trains ST22 and 4MB7. As a direct result of the investigation the ARTC confirmed:

- That a review of the Phoenix replay established that freight train 4MB7 was shown as being in clear on the Up Main line of the network controller's screen despite the fact that it was probably fouling No.1 Platform Road.
- The interface joint between CA74C and CA74D track was established as the design clearance point between the Up Main line and No.1 Platform Road, even though the distance between track centres was less than that mandated by the ARTC, in this case it should have been 2016 mm.
- That the driver of ST22 (XPT) had probably correctly observed that the last wagon of freight train 4MB7 was fouling the path of his train.

As a result of the findings, the ARTC:

- Prohibited all crosses of a similar type pending further investigation.
- Established that a design error had given rise to the signalling irregularity. The ARTC then arranged for corrective action to the signalling system interlocking to prevent recurrence.
- Commenced a full investigation to identify the underlying cause for the signalling design error. The ARTC has since implemented a series of strategies (see Section 4 of this report - Safety Action) aimed at minimising the risk of a similar occurrence.

The Australian Transport Safety Bureau was satisfied with the initial response and action taken by the Australian Rail Track Corporation to address the reported signalling irregularity at Cootamundra involving trains ST22 and 4MB7.

### 3.1 Context

At about 0217 on Thursday 12 November 2009 train ST22, an XPT passenger service, was being routed into No.1 Platform Road at Cootamundra, New South Wales. The driver of the XPT received a Medium Turnout indication on signal CA74 signifying that the route into No.1 Platform Road was set and unobstructed. Shortly after passing over the Gundagai Road level crossing and traversing 136 points set reverse the driver of the XPT observed the last wagon of freight train 4MB7, located on the Up Main line, was obstructing the path of his train. He applied the train brakes and stopped just short of train 4MB7.

From the evidence available, the following findings are made with respect to the incident and should not be read as apportioning blame or liability to any particular organisation or individual.

### 3.2 Contributing safety factors

- Signal CA74 cleared for the passage of the XPT even though the route was fouled by the last wagon of train 4MB7.
- The centre line distance between the Up Main line and No. 1 Platform Road at the interface between CA74D and CA74C track was 1410 mm. The minimum distance to prevent fouling between the two tracks at the location should have been 2016 mm.
- The South Improvement Alliance engineers did not effectively identify and record that the interface between CA74C and CA74D was the fouling point between the Up Main line and No.1 Platform Road and thus did not recognise that the rear of a train sitting on the Up Main line at this location would foul No.1 Platform Road. The design deficiency was caused by a long standing practice of not explicitly recording the clearance point on the Signal Arrangement Plan, Track Insulation Plan or in the Control Tables. *[Significant safety issue]*
- A design based on using a clearance point at the interface of CA74C and CA74D should not have been implemented until it was established that the clearance between the Up Main line and No.1 Platform Road at the interface of CA74C and CA74D tracks was adequate. *[Minor safety issue]*
- The documentation and quality control processes used by the South Improvement Alliance for the Cootamundra re-signalling project were not sufficiently robust, in particular, the closing out of identified design issues was inadequate. *[Significant safety issue]*

### 3.3 Other safety factors

- Although the Australian Rail Track Corporation was not resourced to actively participate in the design or commissioning phases of the Cootamundra re-signalling project, greater involvement by the Australian Rail Track Corporation (local knowledge of site geography and layout)

during these phases may have assisted the South Improvement Alliance engineers in detecting the design error. *[Minor safety issue]*

- As the re-signalling of Cootamundra neared completion it became necessary to undertake control table and software development concurrently to meet the targeted commissioning date. Normally control table and software development is done sequentially to ensure that all the control table logic is fully reflected in the final software and associated validation/testing processes. *[Minor safety issue]*
- Where a design involves complex signalling arrangements, it may be beneficial to involve the designing engineer during the final onsite field testing phase as they have the best understanding of the interlocking principles. This places them in a strong position to identify any design omissions or deficiencies that may not have been evident during earlier phases of a project. *[Minor safety issue]*
- Where a signalling design has implicit safety requirements that need to be validated onsite, field testers should be provided with comprehensive check notes and/or clearly annotated information that ensures specific testing requirements are not omitted. *[Minor safety issue]*
- The network controller and Australian Rail Track Corporation operations manager did not recognise the Cootamundra signalling irregularity as a wrong side failure and therefore did not respond in accordance with established Australian Rail Track Corporation procedures and in a timely manner.

### **3.4 Other key findings**

- The investigation established that the network controller's screen showed freight train 4MB7 in clear on the Up Main line despite the fact that the train was obstructing No.1 Platform Road. The network controller's actions were appropriate in the circumstances.
- Analysis of the data logs from the XPT and 4MB7 established that both trains were managed and driven in an appropriate manner.
- The 'End of Train Marker' (flashing red light) fitted to the last wagon of freight train 4MB7 probably alerted the driver of the XPT to the presence of 4MB7.
- The observations by the driver of the XPT were correct, in that the rear of freight train 4MB7 was probably obstructing the path of the XPT even though signal CA74 gave a proceed indication.
- On observing that the rear wagon of train 4MB7 was probably fouling the path of his train, the driver of the XPT acted professionally and quickly, bringing his train to a stand, thereby avoiding a collision with train 4MB7.
- The train drivers were appropriately trained, qualified and fit-for-duty at the time of the incident. There were no crew performance issues that would have contributed to the incident.

- The investigation established that the signal designers and checkers used by the South Improvement Alliance for the Cootamundra signalling project had extensive experience and were used in such a way as to ensure best available experience and greatest opportunity for project continuity.
- There were no mechanical deficiencies with either train 4MB7 or the XPT which would have contributed to the incident.
- There were no deficiencies in track condition that would have contributed to the incident.